

doorsnede 09c/c1

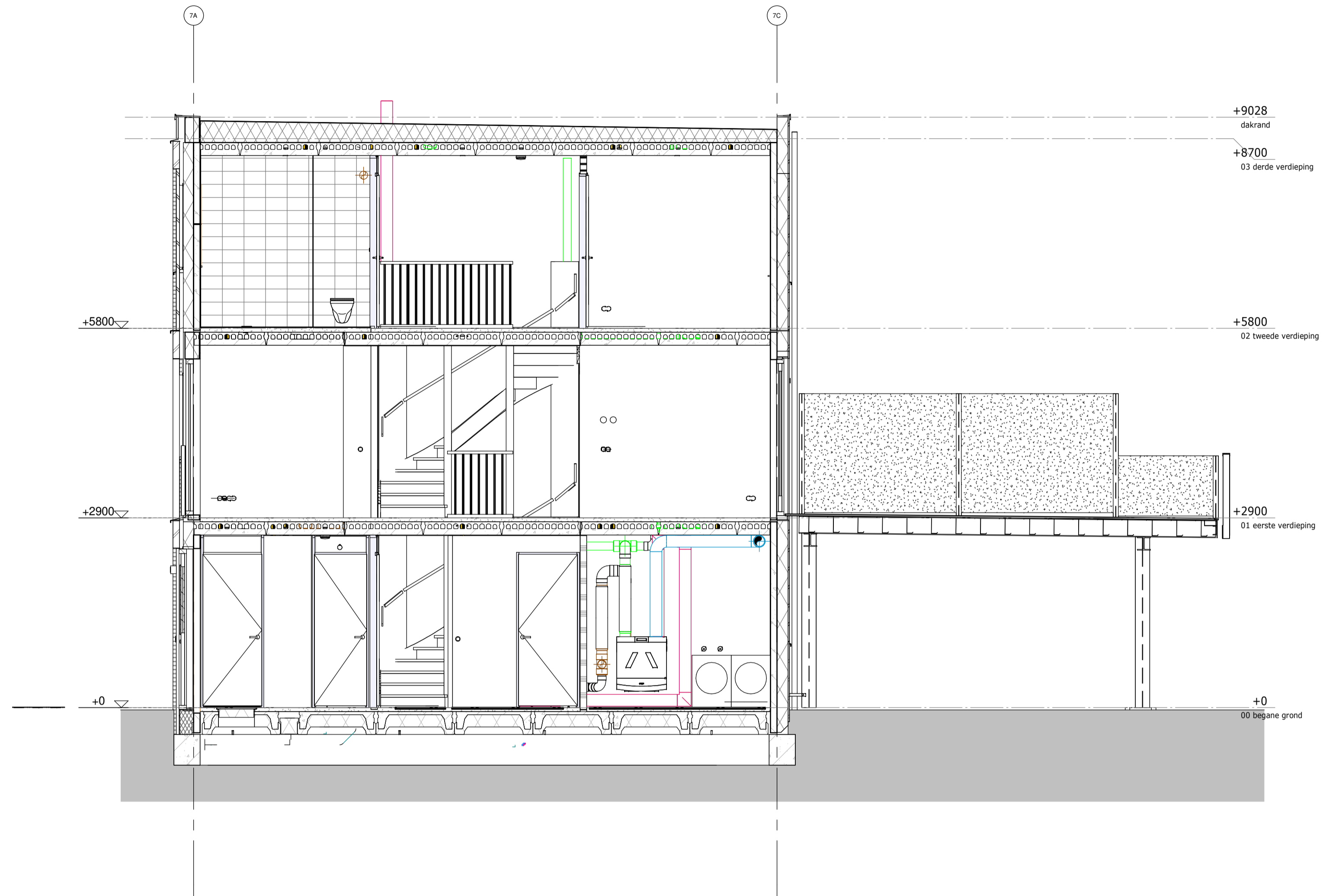

doorsnede 09d/c2

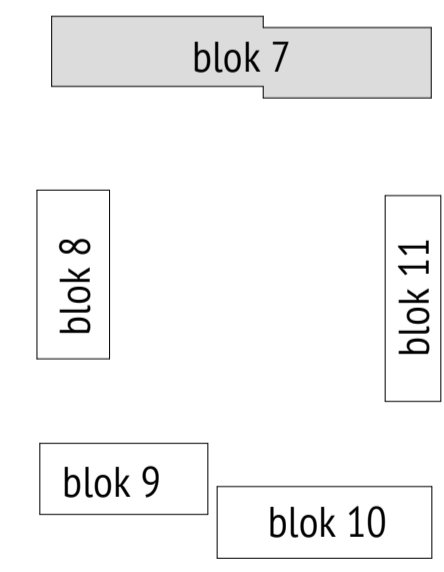

DAAD

DAAD Architecten B.V.
 Patz 21
 9411 PM
 Beilen
 Nederland
 +31 (0)595 582 450
 info@daad.nl

opdrachtgever	Trebbe Wonen
werk	Newton Park Enschede
onderwerp	Blok 7 - Doorsnedes
gewijzigd	
a.	datum 01-10-2022
b.	schaal 1:50
c.	formaat A1
d.	werknr. 20008
e.	
f.	bladnr. DO.07.202
g.	